

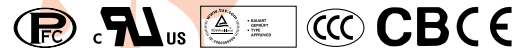

■ Features :

- Universal AC input / Full range
- Built-in active PFC function, PF>0.95
- Protections: Short circuit / Overload / Over voltage / Over temperature
- Forced air cooling by built-in DC Fan
- 1U low profile 30mm
- Optional conformal coating (RSP-320-□CC)
- Built-in fan speed control
- LED indicator for power on
- 3 years warranty



SPECIFICATION

MODEL	RSP-320-2.5	RSP-320-3.3	RSP-320-4	RSP-320-5	RSP-320-7.5	RSP-320-12	
OUTPUT	DC VOLTAGE	2.5V	3.3V	4V	5V	7.5V	12V
	RATED CURRENT	60A	60A	60A	60A	40A	26.7A
	CURRENT RANGE	0 ~ 60A	0 ~ 60A	0 ~ 60A	0 ~ 60A	0 ~ 40A	0 ~ 26.7A
	RATED POWER	150W	198W	240W	300W	300W	320.4W
	RIPPLE & NOISE (max.) Note.2	100mVp-p	100mVp-p	100mVp-p	150mVp-p	150mVp-p	150mVp-p
	VOLTAGE ADJ. RANGE	2.35 ~ 2.75V	3.14 ~ 3.63V	3.7 ~ 4.3V	4.5 ~ 5.5V	6 ~ 9V	10 ~ 13.2V
	VOLTAGE TOLERANCE Note.3	±2.0%	±2.0%	±2.0%	±2.0%	±2.0%	±1.0%
	LINE REGULATION	±0.5%	±0.5%	±0.5%	±0.5%	±0.5%	±0.3%
	LOAD REGULATION	±1.5%	±1.5%	±1.0%	±1.0%	±1.0%	±0.5%
	SETUP, RISE TIME	800ms, 50ms/230VAC 2500ms, 50ms/115VAC at full load					
HOLD UP TIME (Typ.)	8ms at full load 230VAC /115VAC						
INPUT	VOLTAGE RANGE Note.5	88 ~ 264VAC 124 ~ 370VDC					
	FREQUENCY RANGE	47 ~ 63Hz					
	POWER FACTOR (Typ.)	PF>0.95/230VAC PF>0.98/115VAC at full load					
	EFFICIENCY (Typ.)	76%	80%	81%	82%	84%	87%
	AC CURRENT (Typ.)	2.5A/115VAC	1.5A/230VAC		5A/115VAC	2.5A/230VAC	
	INRUSH CURRENT (Typ.)	20A/115VAC	40A/230VAC				
	LEAKAGE CURRENT	<1mA / 240VAC					
PROTECTION	OVERLOAD	105 ~ 135% rated output power Protection type : Hiccup mode, recovers automatically after fault condition is removed					
	OVER VOLTAGE	2.88 ~ 3.38V	3.8 ~ 4.5V	4.5 ~ 5.3V	5.75 ~ 6.75V	9.4 ~ 10.9V	13.8 ~ 16.2V
	OVER TEMPERATURE	80°C ±5°C (TSW1) detect on heatsink of power transistor Protection type : Shut down o/p voltage, recovers automatically after temperature goes down					
ENVIRONMENT	WORKING TEMP.	-30 ~ +70°C (Refer to "Derating Curve")					
	WORKING HUMIDITY	20 ~ 90% RH non-condensing					
	STORAGE TEMP., HUMIDITY	-40 ~ +85°C, 10 ~ 95% RH					
	TEMP. COEFFICIENT	±0.03%/°C (0 ~ 50°C)					
	VIBRATION	10 ~ 500Hz, 2G 10min./1cycle, 60min. each along X, Y, Z axes					
SAFETY & EMC (Note 4)	SAFETY STANDARDS	UL60950-1, TUV EN60950-1, CCC GB4943 approved					
	WITHSTAND VOLTAGE	I/P-O/P:3KVAC I/P-FG:1.5KVAC O/P-FG:0.5KVAC					
	ISOLATION RESISTANCE	I/P-O/P, I/P-FG, O/P-FG:100M Ohms / 500VDC / 25°C / 70% RH					
	EMC EMISSION	Compliance to EN55022 (CISPR22) Class B, EN61000-3-2,-3, GB9254 Class B					
	EMC IMMUNITY	Compliance to EN61000-4-2,3,4,5,6,8,11, EN55024, light industry level, criteria A					
OTHERS	MTBF	K hrs min. MIL-HDBK-217F (25°C)					
	DIMENSION	215*115*30mm (L*W*H)					
	PACKING	0.9Kg					
NOTE	<p>1. All parameters NOT specially mentioned are measured at 230VAC input, rated load and 25°C of ambient temperature.</p> <p>2. Ripple & noise are measured at 20MHz of bandwidth by using a 12" twisted pair-wire terminated with a 0.1uf & 47uf parallel capacitor.</p> <p>3. Tolerance : includes set up tolerance, line regulation and load regulation.</p> <p>4. The power supply is considered a component which will be installed into a final equipment. The final equipment must be re-confirmed that it still meets EMC directives. For guidance on how to perform these EMC tests, please refer to "EMI testing of component power supplies." (as available on http://www.meanwell.com)</p> <p>5. Derating may be needed under low input voltages. Please check the derating curve for more details.</p>						



■ Features :

- Universal AC input / Full range
- Built-in active PFC function, PF>0.95
- Protections: Short circuit / Overload / Over voltage / Over temperature
- Forced air cooling by built-in DC Fan
- 1U low profile 30mm
- Optional conformal coating (RSP-320-□CC)
- Built-in fan speed control
- LED indicator for power on
- 3 years warranty



SPECIFICATION

MODEL	RSP-320-13.5	RSP-320-15	RSP-320-24	RSP-320-27	RSP-320-36	RSP-320-48	
OUTPUT	DC VOLTAGE	13.5V	15V	24V	27V	36V	48V
	RATED CURRENT	23.8A	21.4A	13.4A	11.9A	8.9A	6.7A
	CURRENT RANGE	0 ~ 23.8A	0 ~ 21.4A	0 ~ 13.4A	0 ~ 11.9A	0 ~ 8.9A	0 ~ 6.7A
	RATED POWER	321.3W	321W	321.6W	321.3W	320.4W	321.6W
	RIPPLE & NOISE (max.) Note.2	150mVp-p	150mVp-p	150mVp-p	200mVp-p	220mVp-p	240mVp-p
	VOLTAGE ADJ. RANGE	12 ~ 15V	13.5 ~ 18V	20 ~ 26.4V	26 ~ 31.5V	32.4 ~ 39.6V	41 ~ 56V
	VOLTAGE TOLERANCE Note.3	±1.0%	±1.0%	±1.0%	±1.0%	±1.0%	±1.0%
	LINE REGULATION	±0.3%	±0.3%	±0.2%	±0.2%	±0.2%	±0.2%
	LOAD REGULATION	±0.5%	±0.5%	±0.5%	±0.5%	±0.5%	±0.5%
	SETUP, RISE TIME	800ms, 50ms/230VAC 2500ms, 50ms/115VAC at full load					
HOLD UP TIME (Typ.)	8ms at full load 230VAC /115VAC						
INPUT	VOLTAGE RANGE Note.5	88 ~ 264VAC	124 ~ 370VDC				
	FREQUENCY RANGE	47 ~ 63Hz					
	POWER FACTOR (Typ.)	PF>0.95/230VAC		PF>0.98/115VAC at full load			
	EFFICIENCY (Typ.)	87%	87%	88%	89%	89%	90%
	AC CURRENT (Typ.)	5A/115VAC	2.5 A/230VAC				
	INRUSH CURRENT (Typ.)	20A/115VAC	40A/230VAC				
	LEAKAGE CURRENT	<1mA / 240VAC					
PROTECTION	OVERLOAD	105 ~ 135% rated output power Protection type : Hiccup mode, recovers automatically after fault condition is removed					
	OVER VOLTAGE	15.7 ~ 18.4V	18.8 ~ 21.8V	27.6 ~ 32.4V	32.9 ~ 38.3V	41.4 ~ 48.6V	58.4 ~ 68V
	OVER TEMPERATURE	80°C ±5°C (TSW1) detect on heatsink of power transistor Protection type : Shut down o/p voltage, re-power on to recover					
ENVIRONMENT	WORKING TEMP.	-30 ~ +70°C (Refer to "Derating Curve")					
	WORKING HUMIDITY	20 ~ 90% RH non-condensing					
	STORAGE TEMP., HUMIDITY	-40 ~ +85°C, 10 ~ 95% RH					
	TEMP. COEFFICIENT	±0.03%/°C (0 ~ 50°C)					
	VIBRATION	10 ~ 500Hz, 2G 10min./1cycle, 60min. each along X, Y, Z axes					
SAFETY & EMC (Note 4)	SAFETY STANDARDS	UL60950-1, TUV EN60950-1, CCC GB4943 approved					
	WITHSTAND VOLTAGE	I/P-O/P:3KVAC I/P-FG:1.5KVAC O/P-FG:0.5KVAC					
	ISOLATION RESISTANCE	I/P-O/P, I/P-FG, O/P-FG:100M Ohms / 500VDC / 25°C / 70% RH					
	EMC EMISSION	Compliance to EN55022 (CISPR22) Class B, EN61000-3-2,-3, GB9254 Class B					
	EMC IMMUNITY	Compliance to EN61000-4-2,3,4,5,6,8,11, EN55024, light industry level, criteria A					
OTHERS	MTBF	K hrs min. MIL-HDBK-217F (25°C)					
	DIMENSION	215*115*30mm (L*W*H)					
	PACKING	0.9Kg					
NOTE	<p>1. All parameters NOT specially mentioned are measured at 230VAC input, rated load and 25°C of ambient temperature.</p> <p>2. Ripple & noise are measured at 20MHz of bandwidth by using a 12" twisted pair-wire terminated with a 0.1uf & 47uf parallel capacitor.</p> <p>3. Tolerance : includes set up tolerance, line regulation and load regulation.</p> <p>4. The power supply is considered a component which will be installed into a final equipment. The final equipment must be re-confirmed that it still meets EMC directives. For guidance on how to perform these EMC tests, please refer to "EMI testing of component power supplies." (as available on http://www.meanwell.com)</p> <p>5. Derating may be needed under low input voltages. Please check the derating curve for more details.</p>						

Mechanical Specification

Case No. Unit:mm

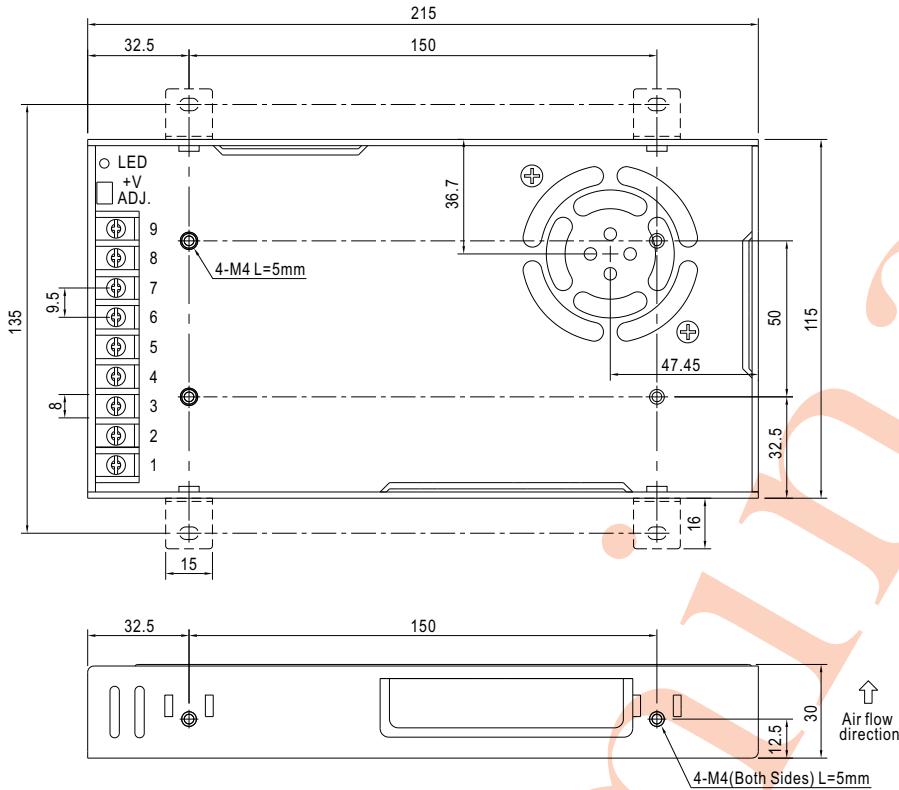

Terminal Pin No. Assignment :

Pin No.	Assignment	Pin No.	Assignment
1	AC/L	4~6	DC OUTPUT -V
2	AC/N	7~9	DC OUTPUT +V
3	FG \perp		

Block Diagram

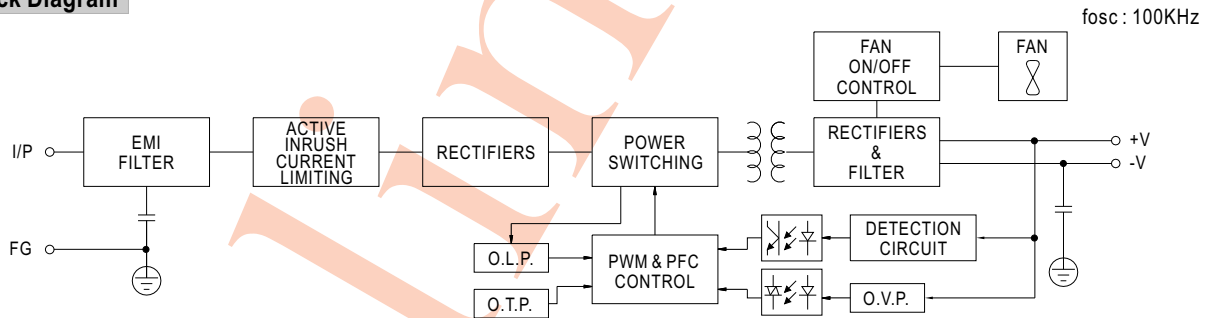

Derating Curve

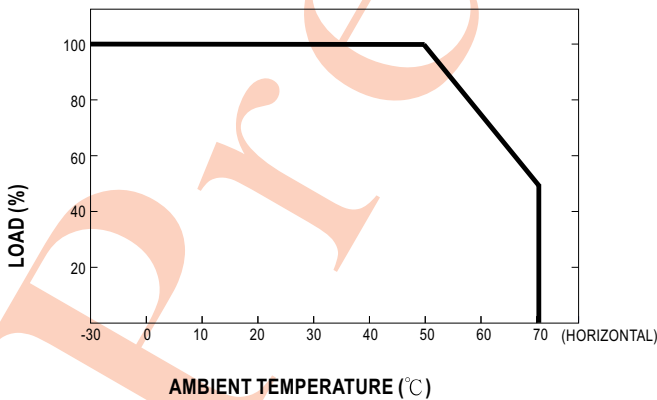

Static Characteristics

